

\* TO PREVENT SIDES FROM WRINKLING WHILE INSTALLING SCREWS, BUYER MAY CONSIDER PRE-DRILLING HOLES THRU BUNKAPS USING AN  $\phi 1/8"$  BIT JUST AFTER SLIPPING THE BUNKAPS OVER THE WOOD BUNKS. DO NOT OVER-TIGHTEN BUNKAP SCREWS; THIS CAN DAMAGE THE SIDE PANELS & WEAKEN THE ASSEMBLY.

## Non-Marking Vinyl BUNKAPS<sup>®</sup> by HARLEY CORP.

PATENTED IN DESIGN, MATERIAL & USE. ALL RIGHTS RESERVED.

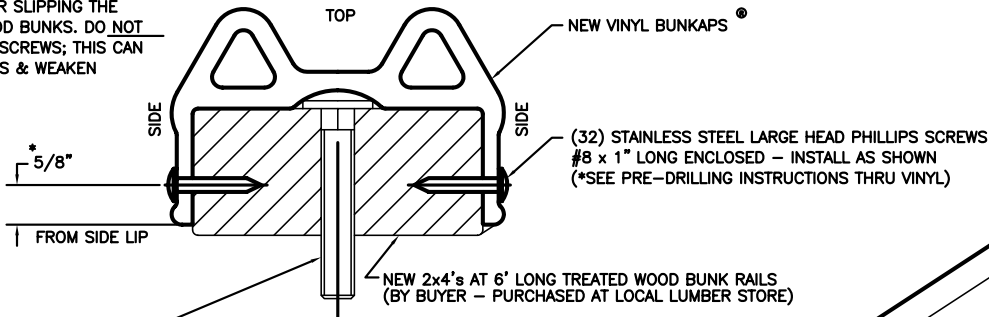

3/8" NEW CARRIAGE BOLT THRU WOOD BUNKS W/FLAT WASHER & NUT (BY BUYER)  
LENGTH & LOCATION DETERMINED BY EXISTING TRAILER BRACKETS; INSTALL IN CENTER.  
IF TWO ARE REQUIRED PER BRACKET, COUNTER-BORE THEIR HEADS FLUSH WITH WOOD.

IF BUYER IS USING A POWERED SCREWDRIVER OR DRILL, BE EXTREMELY CAREFUL TO LIMIT THE OUTPUT TORQUE. OVER-TIGHTENING WILL DAMAGE THE BUNKAP'S SIDE PANELS BEYOND REPAIR. USE HAND TYPE SCREWDRIVER FOR FINAL TIGHTENING TO PREVENT ANY DAMAGE. IF BUYER SHOULD DAMAGE A SIDE PANEL, TRY USING A STAINLESS STEEL FLAT WASHER JUST BENEATH THE SCREW'S HEAD FOR IMMEDIATE REPAIR. REMEMBER, ADDITIONAL STAINLESS STEEL SCREWS CAN BE ADDED FOR MORE STRENGTH.

HARLEY CORPORATION  
PO BOX 4046  
EVANSVILLE, IN 47724-4046

PHONE: 800.463.0347

**PATENTED**  
**6,651,997 B2**

### BRIEF STEP-BY-STEP INSTALLATION:

1. COMPLETELY REMOVE OLD WORN-OUT CARPETED BUNKS.
2. PURCHASE TWO NEW PRESSURE-TREATED WOODEN BUNKS.
3. MEASURE TRAILER BRACKET HOLES FOR EXACT LOCATION.
4. PREDRILL CARRIAGE MT'G BOLT HOLES THRU WOOD BUNK.
5. INSTALL NEW CARRIAGE BOLTS & PRETEST ON TRAILER.
6. SLIP BUNKAPS OVER EACH WOOD BUNK TIGHTLY.
7. MEASURE & MARK SIDE SCREW LOCATIONS.
8. DRILL  $\phi 1/8$  HOLES THRU BUNKAP SIDES.
9. RECHECK FOR TIGHT FIT TO WOOD.
10. INSTALL ALL STAINLESS SCREWS.
11. INSTALL BUNKS & BUNKAPS.

### INSTALL BUNKAPS WITH 3/4" OVERHANG AT EACH END

THIS PREVENTS WATERCRAFT FROM STRIKING WOODEN BUNK ENDS.  
OR BUYER MAY ELECT TO TRIM ENDS OFF EVEN WITH BUNK (USING POWERED CHOP SAW OR UTILITY KNIFE).

FOR MORE INFORMATION, SEE OUR WEBSITE - [www.bunkaps.com](http://www.bunkaps.com) or [www.harleycorp.com](http://www.harleycorp.com)

### SPECIAL NOTE:

AT COMPLETION OF ASSEMBLY TO YOUR TRAILER, RE-ADJUST BUNKS TO RIDE IN THE PATH BETWEEN THE WATERCRAFT'S HULL "RIBS" FOR BEST RESULTS. SHOULD YOUR BUNKAPS BEGIN TO HAVE A "POWDERY-DRY" SURFACE OR A STICKY HIGH FRICTIONAL SURFACE, THEN SIMPLY APPLY A LIBERAL AMOUNT OF BABY OIL (OR SIMILAR PRODUCT) TO THE BUNKAPS' HIGH-POINT SURFACES; THIS HELPS TO LOWER THE FRICTION.

